

# Scape®

# Movable 65"

smo65-009-01

Operating instructions

# Scape® Movable

## Operating instructions

### Contents

<b>1. General information</b>	<b>5</b>
1.1. Safety instructions	5
1.2. Scope of delivery	7
1.3. Cleaning information	8
1.4. Transportation instructions	8
<b>2. Function and structure</b>	<b>9</b>
2.1. Connections & controls	9
2.1.1. Lift- Power supply	9
2.1.2. Lift control	10
2.1.3. Integrated MiniPC 3060	11
2.1.4. Touch screen	13
2.1.5. Remote control	14
<b>3. Connect</b>	<b>15</b>
3.1. Overview	15
3.2. Notes	15
3.3. Connection to the power supply	15
3.4. Connection to the network	16
<b>4. Switch on</b>	<b>16</b>
<b>5. Instructions for use</b>	<b>17</b>
<b>6. Screen settings - OSD</b>	<b>18</b>
6.1. Using the OSD (on-screen display)	18
6.2. Select image source	18
<b>7. Integrated PC</b>	<b>19</b>
<b>8. Troubleshooting tips</b>	<b>20</b>
8.1. Manufacturer - Support	20
8.2. Problems and solutions	21
<b>9. Appendix</b>	<b>23</b>
9.1. Technical data	23
9.1.1. Scape® Movable 65 (Mini-PC 3060)	23
9.1.2. Scape® Tangible 65	23
9.1.3. Mini-PC 3060	25

-

9.2. Technical drawings	26
9.2.1. Perspective	26
9.2.2. Horizontal - top view	27
9.2.3. Horizontal - front view (high)	28
9.2.5. Horizontal - front view (deep)	29
9.2.6. Horizontal - side view, right (high)	30
9.2.7. Horizontal - side view, right (low)	31
9.2.8. Vertical - top view	32
9.2.9. Vertical - front view (high)	33
9.2.10. Vertical - front view (deep)	34
9.2.11. Vertical - side view, right (high)	35
9.2.12. Vertical - side view, right (deep)	36

## Notes

This is a class A device according to EN55022.

Please also

read [1.1 Safety instructions](#) - Radio interference and interference.

This device complies with Part 15 of the FCC Rules. Operation is subject to the following two conditions: (1) this device may not cause harmful interference, and (2) this device must accept any interference received, including interference that may cause undesired operation.

This Class A digital apparatus complies with Canadian ICES-003.



This manual applies to the following devices:

- Scape® Movable 55" with MiniPC 3060 (smo55-008-01)

Information in this document is subject to change without notice. ©2024 Interactive Scape GmbH. All rights reserved.

The document or excerpts from the document may not be reproduced without the prior consent of Interactive Scape GmbH.

Interactive Scape GmbH is not liable for errors contained in this document or for any other incidental or consequential damages resulting from the delivery, application or use of this material.

All product names mentioned in this document are trademarks or registered trademarks of their respective owners.

# 1. General information

This manual describes the safe commissioning, configuration and proper operation of the **Scape® Movable**.

If your device does not have an integrated PC, you can skip the chapters and instructions on the integrated PC. All other notes and instructions continue to apply without restriction. Please refer to any supplementary documents, such as installation instructions.

## 1.1. Safety instructions

Before commissioning and during operation of your **Scape® Movable** the following safety instructions to protect yourself, your surroundings and the **Scape® Movable** from damage.

### Fires and electric shocks

Overloaded sockets, extension cables and multiple socket outlets can cause fires and electric shocks.

- Avoid using power strips and extension cables wherever possible.
- Do not connect several extension cables or socket strips together.

### Overheating

Heat build-up can cause the screen and the integrated PC to overheat. This can lead to damage to the device.

- Ensure sufficient air circulation around the **Scape® Movable**.
- Make sure that all ventilation slots on the screen and integrated PC are always clear.

### Surge damage due to lightning

During thunderstorms, there is a risk of overvoltage damage to connected electrical appliances due to lightning strikes.

- Do not install the **Scape® Movable** during thunderstorms.
- Disconnect the appliances from the power supply during thunderstorms.

### Moisture, liquids and vapors

Moisture, liquids and vapors that enter the interior of the **Scape® Movable** can cause electric shocks or short circuits.

- Use the **Scape® Movable** only inside buildings.
- Do not allow any liquids to enter the inside of the **Scape® Movable**.
- Protect your **Scape® Movable** from vapors and moisture.

## Improper cleaning

Improper cleaning with harsh cleaning agents and solvents or dripping wet cloths can damage the **Scape® Movable**.

- Please note the information on cleaning your **Scape® Movable** (Chapter 1.3 Information on cleaning).

## Improper opening and repair

Improper opening and improper repairs can result in hazards for users of the appliances.

- Do not open the housing of the devices.
- Contact the manufacturer or specialist retailer if you need repairs.

## Radio interference and interference

Radio interference can be generated by any device that emits electromagnetic signals. Due to the large number of devices that transmit and receive radio waves, interference can be caused by overlapping radio waves.

- Use the **Scape® Movable** in places where the use of radio equipment is prohibited.
- Especially in hospitals, outpatient health centers, doctors' surgeries and other medical facilities, follow the instructions and directions of authorized persons to switch off radio devices in order to avoid interference with sensitive medical equipment.
- Ask your doctor or the manufacturer of your medical device (pacemaker, hearing aid, implant with electronic control, etc.) whether it is compatible with the use of your **Scape® Movable** and works without interference.
- If necessary, maintain the minimum distance of 15 cm recommended by medical device manufacturers to avoid interference with your medical device.

## Explosive environments

Under unfavorable circumstances, radio waves can cause fire or explosions in the vicinity of potentially explosive atmospheres.

- Do not install and operate the **Scape® Movable** near potentially explosive atmospheres, flammable gases, areas where the air contains chemicals or particles such as grain, dust or metal powder, or near blasting sites.
- In places with potentially explosive atmospheres and in the vicinity of blasting sites, follow the instructions for switching off electronic devices to avoid interference with the blasting and ignition systems.

## Load and damage to the surface

Rough, hard or sharp-edged materials and heavy objects can damage the screen surface of the **Scape® Movable**.

- Do not place any heavy objects on the screen.
- Only use objects with smooth or soft surfaces on the screen.
- Clean the undersides of the objects before and after each use.

## Notes on the lift frame

Improper or careless handling of the screen with the lift frame can cause damage to your **Scape® Movable** or the surrounding area and can lead to serious injury.

- The lift function of the **Scape® Movable** may only be operated by adults.
- Ensure that there are no furnishings or other objects or persons in the travel range.
- Never reach into the frame during the procedure. There is an acute risk of injury.
- Pay attention to unusual noises or uneven running of the appliance during the process. Stop the process immediately if you notice anything unusual.
- If the control element of the lift frame smells unusual or makes a noise, stop operation immediately and disconnect the appliance from the power supply.
- Always leave the brake device on the lift frame castors activated and only release it when the **Scape® Movable** needs to be moved.
- Tighten the braking device on the lift frame castors again after moving.
- Only move the lift frame fully retracted (lowest position) and in a vertical position.
- Disconnect the appliance from the mains before moving it - pull out the mains plug.

## 1.2. Scope of delivery

The following accessories are included with your **Scape® Movable** is included:

- IEC cable for connection to the power supply
- Wireless keyboard with trackpad
- Infrared remote control (receiver on the back of the device)
- Screen cleaning kit
- Operating instructions (if necessary by e-mail)

### 1.3. Cleaning information

The touch sensor of the **Scape® Movable** does not usually require maintenance. Nevertheless, it is recommended to clean the glass surface of the screen regularly.

- Disconnect the appliance from the power supply before cleaning.
- Typically, a solution of isopropyl alcohol and water (mixing ratio 50:50) or the enclosed screen cleaning kit are best suited for cleaning the touch sensor.
- Apply the solution to a soft, lint-free cloth. Avoid coarse materials.
- Moisten the cloth and clean the glass surface. Only apply the liquid to the cloth and never directly to the appliance. This will prevent liquid from penetrating the inside of the appliance or staining the frame.

### 1.4. Transportation instructions

The safest way to transport your device is in a flight case for the **Scape® Movable** (available separately).

- Place the display in the fully vertical position for transportation and move it to the lowest setting.
- Lock the castors of the lift frame during transportation.
- Secure the device or flight case against slipping and tipping.



## 2. Function and structure

### 2.1. Connections & controls

#### 2.1.1. Lift- Power supply

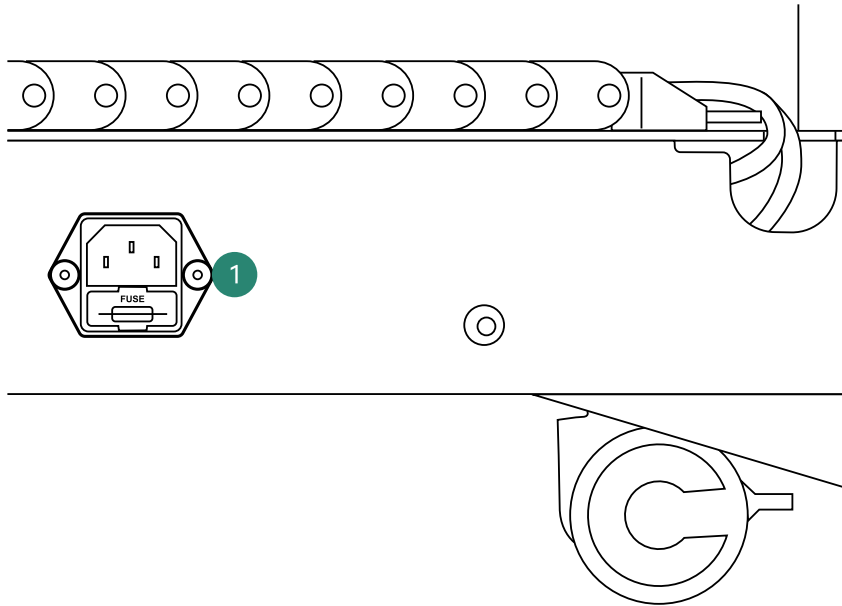

1

IEC connection (230V / 50Hz) - fused

## 2.1.2. Lift control

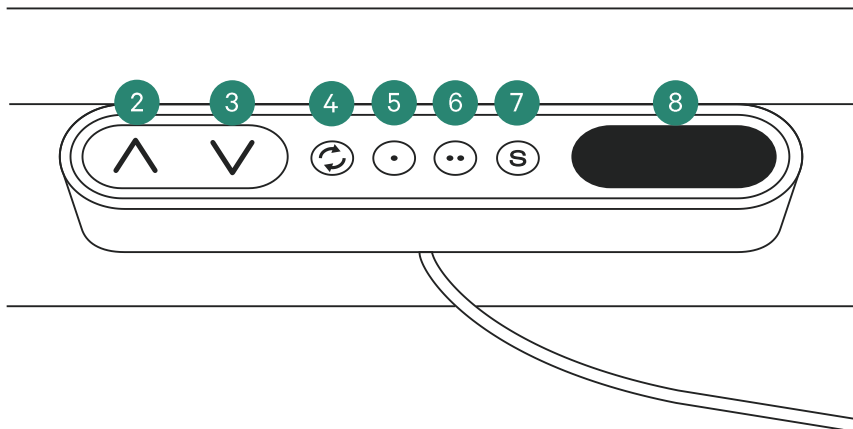

2	Raise screen position (mode 1) & tilt vertically (mode 2)
3	Lower screen position (mode 1) & tilt horizontally (mode 2)
4	Change mode
5	Default setting 1
6	Default setting 2
7	Set up preset
8	Display

You can use the **Scape® Movable** to adjust both the height of the screen and its tilt. Press the mode button **(4)** to switch between the **height adjustment (mode 1)** and **tilt adjustment (mode 2)** modes. After switching the mode, the display **(8)** shows you the respective number. Now set the desired height or tilt of the screen using the buttons for moving the position **(2 & 3)**.

You have the option of saving 2 positions and recalling them later. To do this, set the height and tilt as required. Press the memory button **(7)** for 3 seconds and then select the desired memory location I **(5)** or II **(6)**.

To move to the saved position again later, press and hold the button for the corresponding memory location until the screen is in the saved position.



**Ensure that there is sufficient space around the appliance and that the appliance does not bump into anything during the process.**



**Do not touch the lift frame during the procedure!**

**Only hold the appliance by the control element during the procedure.**

### 2.1.3. Integrated MiniPC 3060

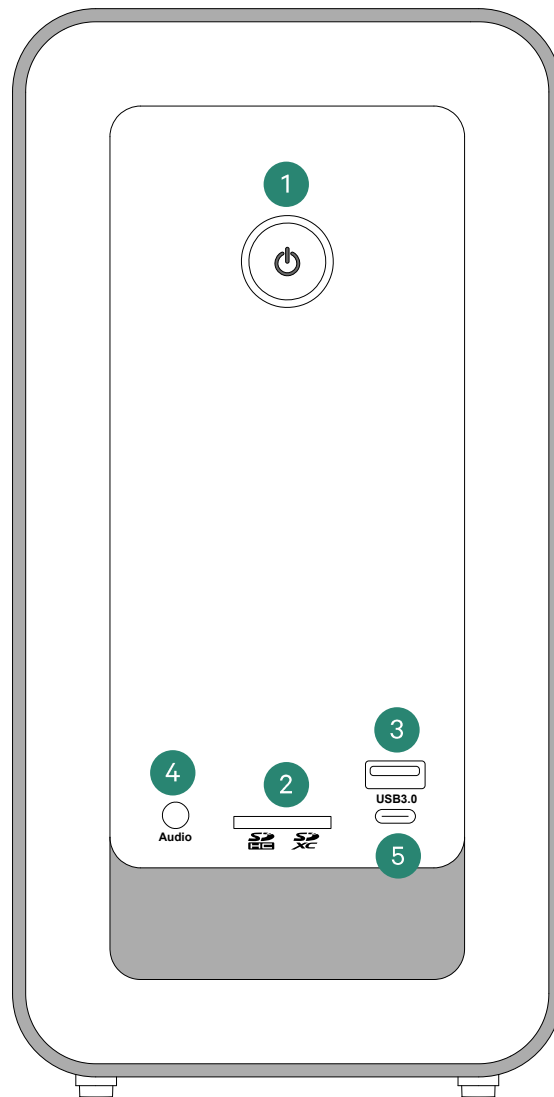

1	Switching the PC on / off
2	SD(HC/XC) slot
3	USB 3.1 (type A)
4	Audio input/output (3.5 mm jack)
5	USB 3.1 (Type C)

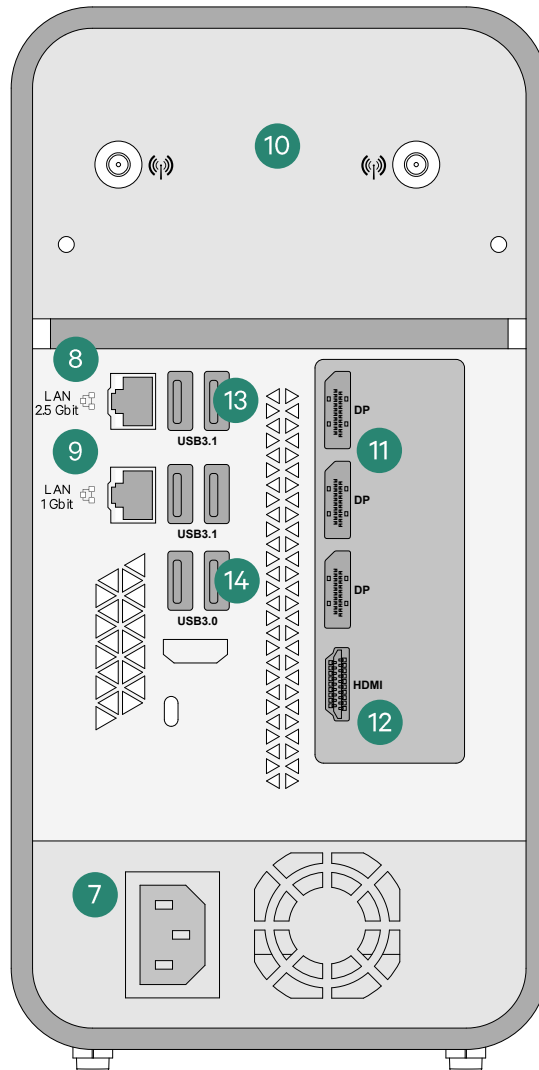

7	Power supply
8	2.5 Gigabit Ethernet (external)
9	1 Gigabit Ethernet (internal - TUIO)
10	2x external Wifi antennas
11	DisplayPort out
12	HDMI 2.0 out
13	USB 3.1 (type A)
14	USB 3.0 (type A)

### 2.1.4. Touch screen

The screen of the **Scape® Movable** is already installed and connected to the integrated PC and ready for operation.

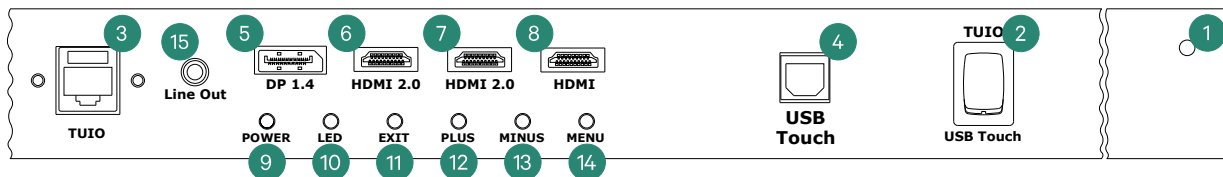

1	IR sensor for remote control
2	Touch TUIO / USB Touch switchover
3	RJ-45 Lan interface - for using the <b>Touch &amp; Object Assistant</b>
4	USB connection type B - for direct connection of touch and PC
5	DisplayPort 1.4 input
6	HDMI 2.0 input (UHD 60 Hz)
7	HDMI 2.0 input (UHD 60 Hz)
8	HDMI 1.4 input
9	Stand-by *(17)
10	Status LED
11	Close OSD / Back / Display input selection *(21)
12	Plus / Right *(23)
13	Minus / Left *(22)
14	OSD displays / confirm selection *(20)
15	Line Out output

\*analogous to the button on the remote control

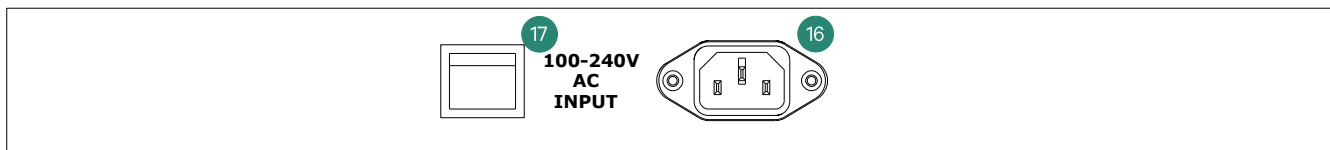

16	IEC socket for connection to 230 V, 50 Hz
17	Main switch of the power supply

### 2.1.5. Remote control

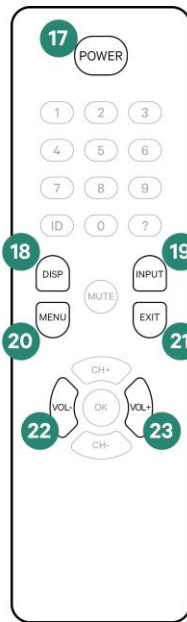

17	Stand-by *(9)
18	Show display mode selection
19	Display input selection
20	OSD displays / confirm selection *(14)
21	Close OSD *(11)
22	Left / Minus *(13)
23	Right / Plus *(12)

\*analogous to the button on the screen

All buttons on the remote control that are not described are not needed to operate the **Scape® Movable** and have no function.

The infrared remote control is located behind the silent PC.

## 3. Connect

### 3.1. Overview

the **Scape® Movable** is supplied ready for use. All devices are fully assembled and wired. Place the appliance in a suitable location and connect it to the mains.

### 3.2. Notes

**Observe the following instructions when setting up the appliance:**

- Give the **Scape® Movable** sufficient time to adjust to the ambient temperature. Otherwise the device may be damaged or destroyed by condensation inside the device.
- Operate the **Scape® Movable** indoors only.
- The **Scape® Movable** may not be exposed to direct sunlight.
- Make sure that there are no obstructions around the **Scape® Movable** and there is sufficient space to move the lift frame.



**Before using your Scape® Movable, remove the red plastic protection on the castors of the lift frame. To do this, pull firmly on the tab on the left and right of each pair of castors.**

### 3.3. Connection to the power supply

Connect the **Scape® Movable** with the supplied power cable via the power connection socket at the base of the device (see **Chapter 2.1.1 - Connections and operating elements - Lift frame - Point 1**) to the mains supply.

To do this, first insert the IEC plug into the corresponding connection and then insert the earthing contact plug into the socket.

When disconnecting the appliance from the mains, always grasp the plug and do not pull on the cable. Do not touch the plug with wet hands.

### 3.4. Connection to the network

The **Scape® Movable** works completely without an Internet or other network connection. Nevertheless, both WLAN and a Gigabit Ethernet port at the base of the device are available for connecting to the Internet or another network.

To use **Scape X®** object recognition or touch via TUIO, set the switch for the touch signal on the back of the display to "TUIO" (see **Chapter 2.1.4 - Connections & operating elements - Touchscreen - Point 2**). For further information on setting up the **Scape X®** object recognition, read the operating instructions for the "**Touch & Object Assistant**".

By default, the integrated **Touch & Object Assistant** has the IP address 10.0.0.20 with the subnet 255.255.255.0, but can also receive IP addresses from a DHCP server. You can access the **Touch & Object Assistant** web interface via the address or the host name on the back of the display. The external Ethernet port (see **chapter 2.1.3 - Connection sockets & operating elements - Integrated PC - 9**) is set to obtain its IP address from a DHCP server.

## 4. Switch on

Switch on the display at the main switch (see **chapter 2.1.4 - Connections & operating elements - Touchscreen - point 16**). Then start the PC (see **chapter 2.1.3 - Connections & operating elements - Integrated PC - point 1**).

The device takes around 1.5 hours to reach its final operating temperature after being switched on. During this time, the device's touch sensor constantly adapts to its environment. This has a direct effect on long-term object detection.



**If object detection does not work properly at any point on the device, remove all objects from the device for 2 seconds.**



## 5. Instructions for use

### Clean the touch sensor and the objects used regularly during operation.

Fine sand and quartz dust in particular can lead to heavy wear on the sensor glass if objects are used intensively. If necessary, use protective films to protect your touch sensor from scratching.

#### **Interesting:**

*We test our objects in robot-supported load tests on our displays for wear and tear on the objects and effects on the sensor disks. For these tests, we let a cobot use objects for approx. 15h / or 10km continuously on a Scape Tangible 55.*

*A distance of 10 km on the sensor corresponds to several years of intensive use of an object.*

*The robot simulates*

*average object use in a "normal" application.*

*It performs random translational and rotational movements with the object on the display.*

*The object is repeatedly lifted up and placed back down in another area of the screen.*

*Only movements during which the object is in contact with the sensor are counted as distance traveled.*

*The force with which the object is pressed onto the screen is approx. 2N.*

*The test environment is neither clean nor excessively dirty.*

*Neither the sensor nor the object are cleaned during a test run.*

***As a result, we have so far been unable to detect any excessive object wear or damage to the sensor glass.***

### Avoid putting too much strain on the touch sensor.

To ensure error-free object detection, the total mass of all objects on the device must not exceed **3 kg**.

### Always ensure that your appliance is sufficiently cooled.

This considerably extends the service life of the installed panel.



**Signs of wear on the sensor and objects are unavoidable under normal use.**

**Avoid an application design that encourages the use of objects on a small exclusive area of the device.**

**Even if the maximum load for the sensor is higher, you should not exceed a weight of 500g per object.**

## 6. Screen settings - OSD

### 6.1. Using the OSD (on-screen display)

The OSD of the **Scape® Movable** offers various setting options for the screen, such as "Signal input", "Display mode" and color and brightness settings.

The factory settings are suitable for most applications.

Press the **Menu** button (20) to display the OSD (see **chapter 2.1.5 - Connections & controls - Remote control**).

Use the **Plus** (23) and **Minus** (22) buttons to navigate through the individual menu items. Press the **Menu** button (20) to go to the next level of the selected menu item or setting.

Use the **Plus** (23) and **Minus** (22) buttons to adjust the values for the respective setting or to select the corresponding option. The **Menu**

button (20) activates the selected option and returns to the last selection level. The **Exit**

button (21) sets the setting to its original value and returns to the next higher menu level or closes the OSD if you are at the top menu level.

The OSD is automatically closed after a few seconds of inactivity.



Abb. 1: Menu opened - select menu item Menu item selected - confirm Setting opened - set value

### 6.2. Select image source

If no active device is connected to the selected input of the screen, you can only use the OSD to a limited extent. Press **Input** (19) or **Exit** (21) on the IR remote control to open the input selection. Use the **Plus** (23) and **Minus** (22) buttons to select the appropriate input and confirm your selection with the **Menu** button (20).

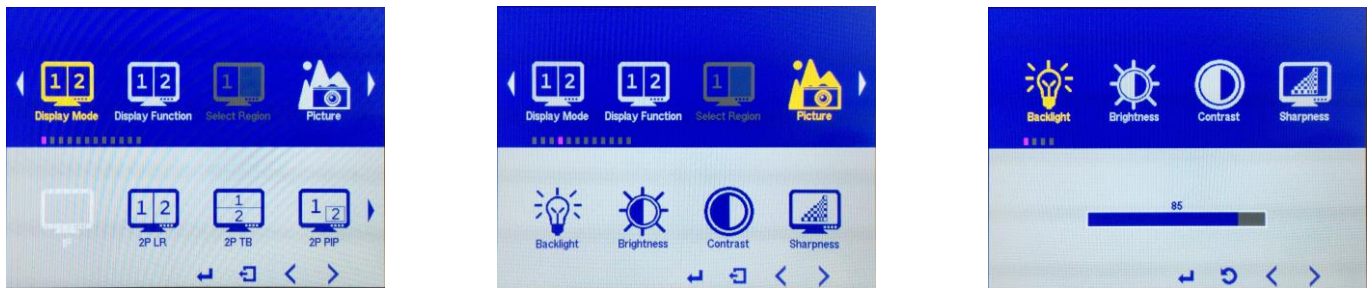

Abb. 2: Input selection

The signal source is set to "Auto" by default and automatically recognizes the corresponding input.

## 7. Integrated PC

Unless you have ordered otherwise, the integrated PC is pre-installed with **Windows 10 Professional**, fully set up and ready to use.



**Before changing the configuration of the operating system and its components, be sure to create a backup. To do this, use the Windows backup tools (Backup settings).**

Your **Scape® Movable** with integrated PC comes with a wireless keyboard with integrated trackpad. Follow the enclosed instructions to set up the keyboard.

To switch on the integrated PC, press the power button on the front of the PC (see **chapter 2.1.3. - Integrated PC - 1**).

A system user with administrator rights and the following access data has already been set up.

User name: ias

Password: ias

For the security of your system, it is strongly recommended that you change the password for this account.

## 8. Troubleshooting tips

Do not open the housing of the **Scape® Movable**, the integrated PC or the lift frame on your own.

If your **Scape® Movable** does not function as intended, refer to **chapter 8.2 - Troubleshooting tips - Problems and solutions** to see if there is a solution to your problem.

If you cannot find a solution, please contact **Interactive Scape Hardware Support**. You can reach them on weekdays on **+49 30 698 094 150**.

### 8.1. Manufacturer - Support

Interactive Scape GmbH  
Wilhelmine-Gemberg-Weg 6  
10179 Berlin

+49 (0)30 698 094 150

## 8.2. Problems and solutions

Error	Possible cause	Possible troubleshooting
<b>The screen shows no picture even though the PC is switched on.</b>	The DisplayPort or HDMI cable is not plugged in correctly	Check DisplayPort or HDMI cable for correct installation  Replace any defective cables
	The screen is switched to the wrong signal input.	Set the signal input correctly
	The screen is switched to standby using the IR remote control or the OSD	Deactivate stand-by mode using the IR remote control or the OSD buttons
	The screen is switched off at the main switch of the device	Switch the appliance on at the main switch of the appliance
<b>Touch and Object Assistant is not available</b>	The screen system has not started correctly	Switch the device off at the main switch, wait 10 seconds and switch it on again. The start-up process takes approx. 1 minute.
	Network cable is not installed correctly	Check that the network cable is correctly installed between the screen and the PC
	Network settings on the PC are not correct	Check the network settings of your PC. The default IP address of your Scape Tangible is 10.0.0.20 (subnet 255.255.255.0)
<b>"No Touch Device Found" is displayed in the Touch and Object Assistant</b>	TUIO / USB touch switch is set to USB touch	Switch the TUIO / USB Touch switch to TUIO Touch
<b>Object tracking does not work in the touch and object test</b>	Invalid Scape X license	Check whether a valid Scape X license is stored on your device
	TUIO / USB touch switch is set to USB touch	Switch the TUIO / USB Touch switch to TUIO Touch
<b>Touch tracking does not work in the touch and object test</b>	TUIO / USB touch switch is set to USB touch	Switch the TUIO / USB Touch switch to TUIO Touch

<b>Objects are poorly recognized</b>	Objects improperly attached to conductive materials	Check whether you are using your Scape X objects in accordance with the specifications in the "Scape X objects" manual
	High electromagnetic radiation in the environment	Calibrate the sensor in Touch and Object
<b>Objects are recognized with incorrect IDs</b>	Objects are used improperly	Check whether you are using your Scape X objects the right way round (top side away from the sensor) or whether you have attached them improperly to conductive material sheets.
	Configuration of the objects in the touch and object test changed	Check the individual incorrectly recognized objects in the Touch and Object Test for changed ID settings

 **Always carry out touch and object recognition tests using the Touch and Object Test in the Touch and Object Assistant. This is the only way you can be sure that the cause of your observations lies in an application or the operating system of the connected PC.**

 **Unfortunately, we cannot provide support for connected PCs that were not supplied by Interactive Scape.**

 **To avoid possible support costs for you, please check whether your problem can be solved with one of the above measures**

## 9. Appendix

### 9.1. Technical data

#### 9.1.1. Scape® Movable 65 (Mini-PC 3060)

Article Number	smo65-009-01
<b>Specifications</b>	
footprint (LxBxH) 0°	152.5 x 89.6 cm
height 0°	95.0 - 160.1 cm
footprint (LxBxH) 90°	152.1 x 70.0 cm
height 90°	122.7 - 187.8 cm
Weight	129 kg
material	steel, powder coated, deep black RAL9005 fine structure
<b>Features</b>	
Display height / tilt angle adjustable	65 cm, 0° - 90°
integrated PC	Mini PC 3060
Rollers	4 lockable rollers
<b>Electrical Specifications</b>	
Operating voltage	230 VAC
Power draw	max. 650 W
Certifications	CE compliant

#### 9.1.2. Scape® Tangible 65

##### Display

Display diagonal	64.5 inches
Resolution	3840 x 2160 (UHD) @60 Hz
Format	16:9
Brightness (Panel)	700 cd/m <sup>2</sup>
Contrast (Panel)	4000:1
Backlight	LED
Viewing angle	178° / 178°
Color gamut	16.7 million

Latency (on/off)		8 ms
Backlight – lifetime		50,000 h
Pixel class		ISO 9241-307 (Pixel Error Class II)
Operational period		24/7
Max. ambient humidity	Operation	10 ~ 90% (not condensing)
Max. ambient humidity	Storage	10 ~ 90% (not condensing)
Max. ambient temperature	Operation	0 ~ 35 °C / 32 ~ 95 °F
Max. ambient humidity	Storage	-20 ~ 60 °C / -4 ~ 140 °F
Dimensions (W x H x D)		1521,5 x 896,4 x 97 mm
Weight		72 kg
Mounting		VESA 400x400 mm, 600x400 mm, 800x400 mm
Max. tipping angle		0° - 180°
Panel orientation		Landscape / Portrait / Flat (table)
Air flow cooling		0.5 m³ / min
Material		steel, powder-coated, matt black

### Touch controller

Sensor		Projective Capacitive (PCAP) - Silver Nanowire
USB Touch		80 touches
TUIO Touch		>100 touches

### Interfaces

Touch		HID USB / TUIO 1.1 / 2.0
Video		2x HDMI 2.0 / 1x HDMI 1.4 / 1x DisplayPort 1.4

### Electrical specifications

Operating voltage		100 – 240 VAC 50/60Hz
Power draw		230 W
Certifications		CE, RoHS, FCC



### 9.1.3. Mini-PC 3060

#### Specifications

Processor	Intel Core i5-10400 6-core 2.9 - 4.3 GHz
RAM	16 GB (Dual Channel)
Hard drive	250 GB SSD M.2
Graphics Card	NVIDIA Geforce RTX 3060 12GB GDDR6
Sound	Onboard 8 Channel Digital Audio via HDMI Mic/Speaker output

#### Ports

Display	1x HDMI 2.1 / 3x DisplayPort 1.4a
Network	WIFI 6 Killer AX1650 / 1x Killer 2.5 Gbps LAN / 1x Gigabit LAN / Bluetooth 5
USB	4x USB 3.1 Type A, 3x USB 3.0 Type A, 1x USB 3.0 Type C

#### Other

Dimensions (LxWxH)	265.5 x 126 x 249 mm
Power Supply	internal power supply unit
Operating voltage	100 – 240 VAC
Power draw	500 W
Operating System	Windows 10 Professional
	not suitable for 24/7 operation

## 9.2. Technical drawings

### 9.2.1. Perspective

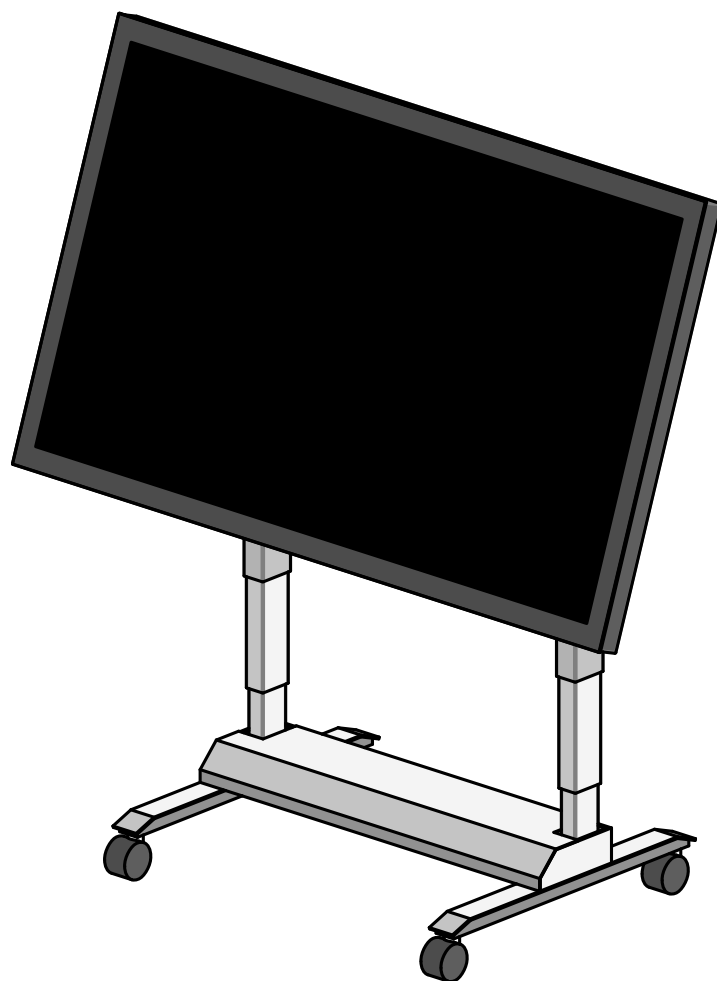

### 9.2.2. Horizontal - top view

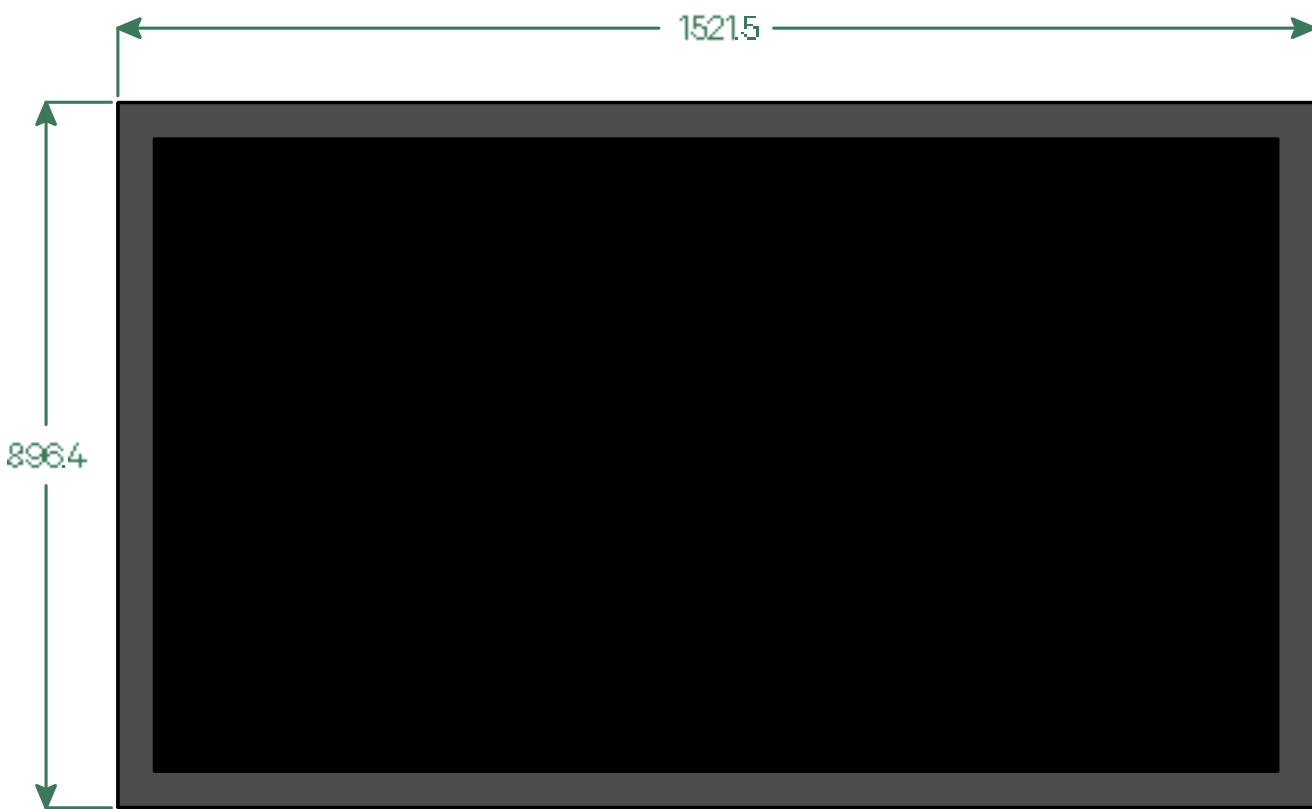

### 9.2.3. Horizontal - front view (high)

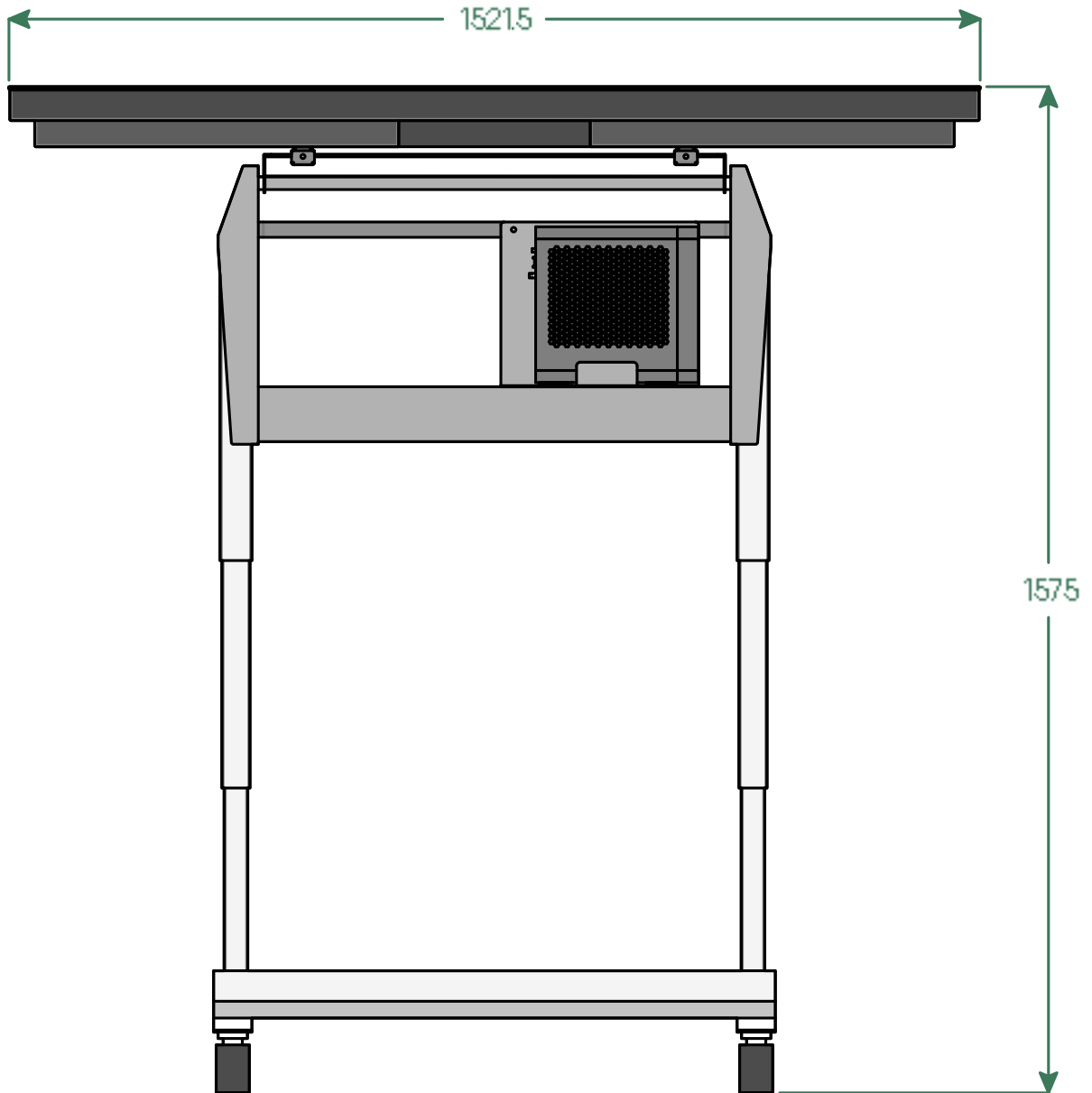

### 9.2.5. Horizontal - front view (deep)

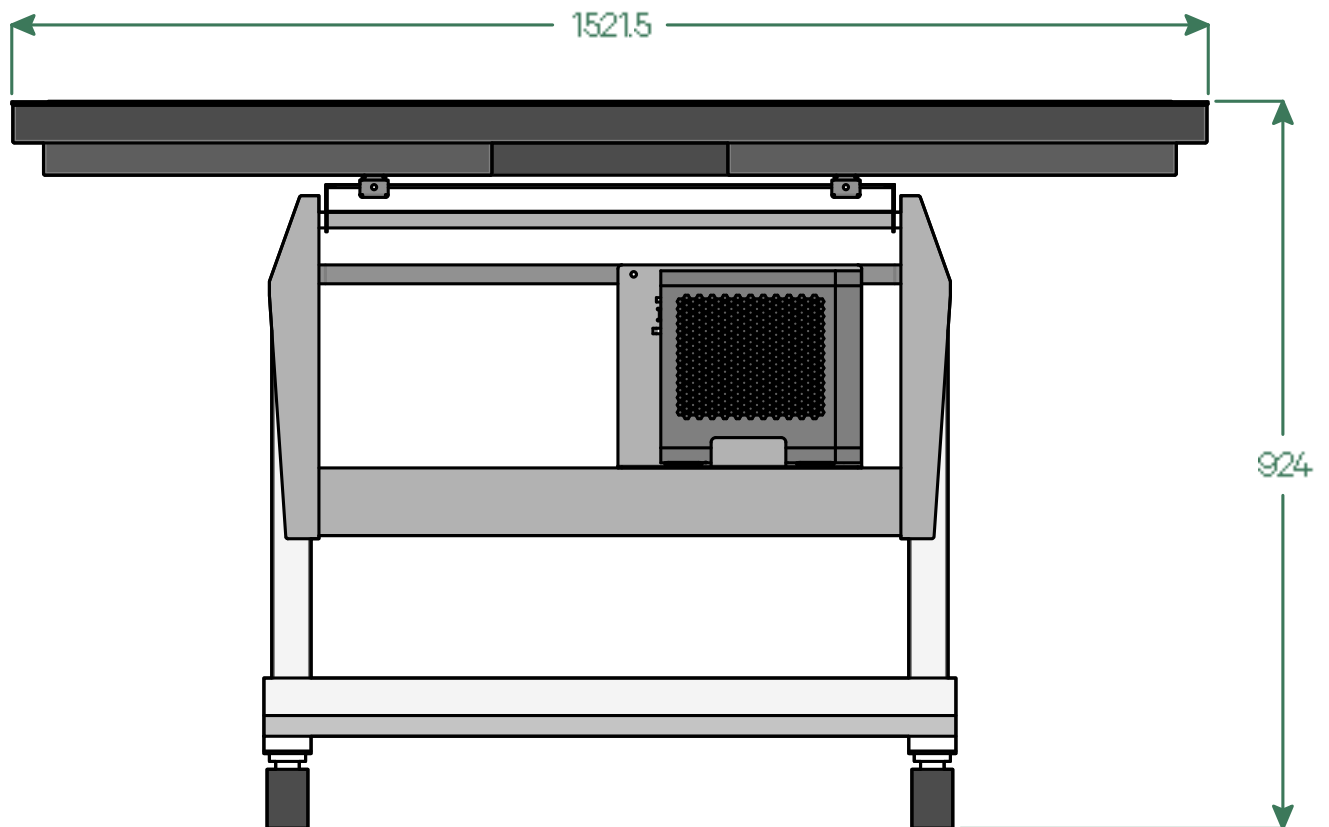

9.2.6. Horizontal - side view, right (high)

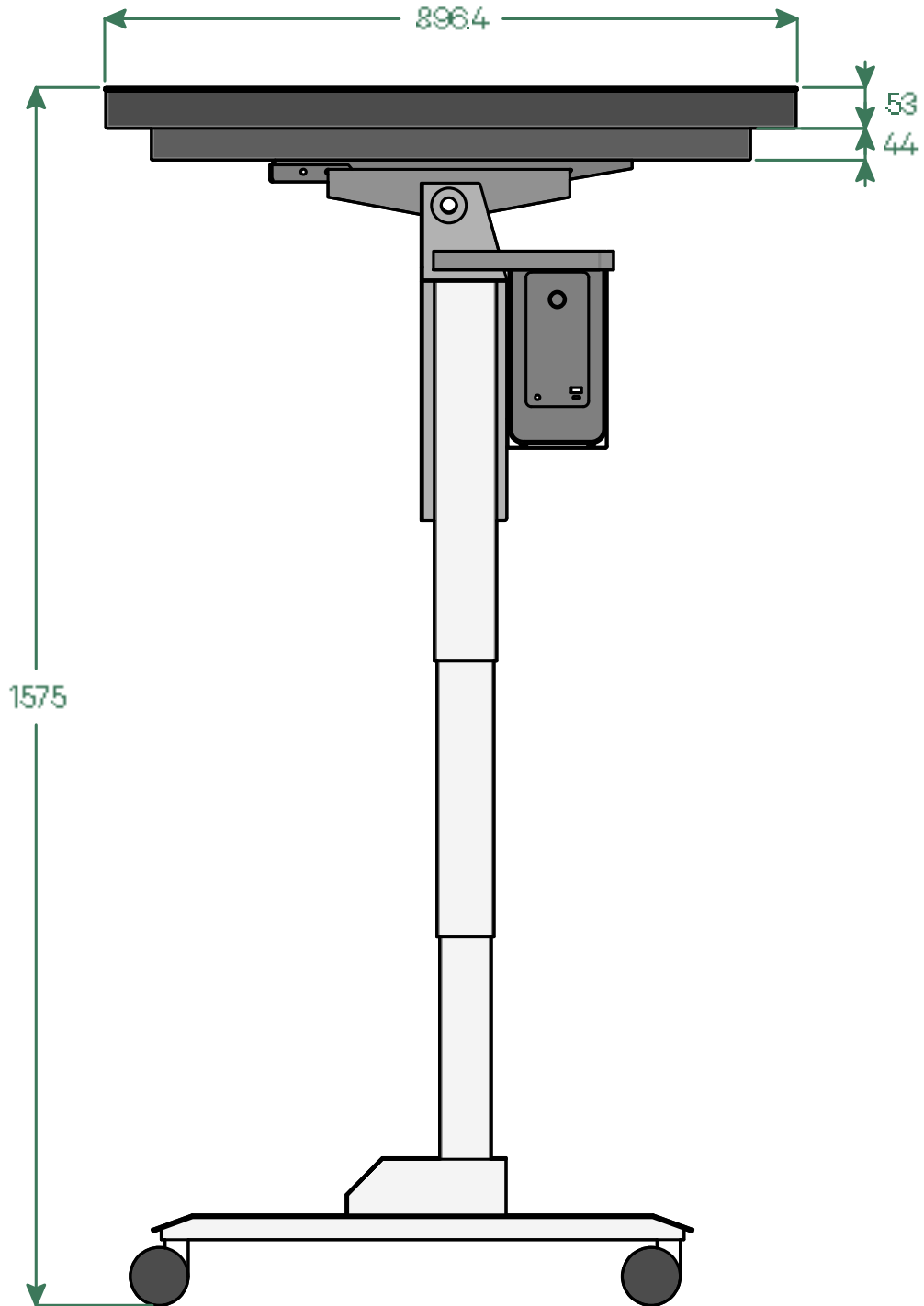

9.2.7. Horizontal - side view, right (low)

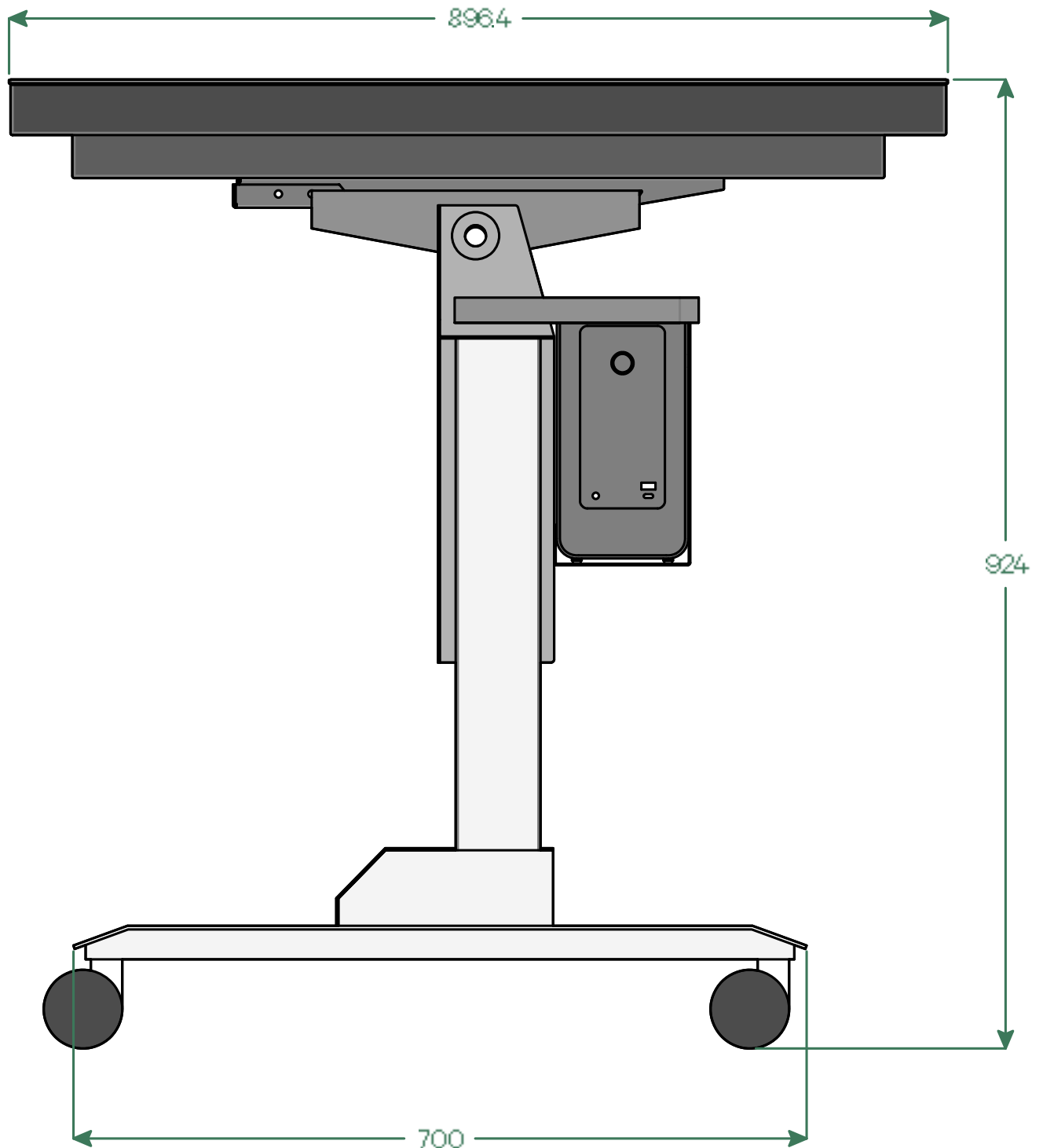

### 9.2.8. Vertical - top view

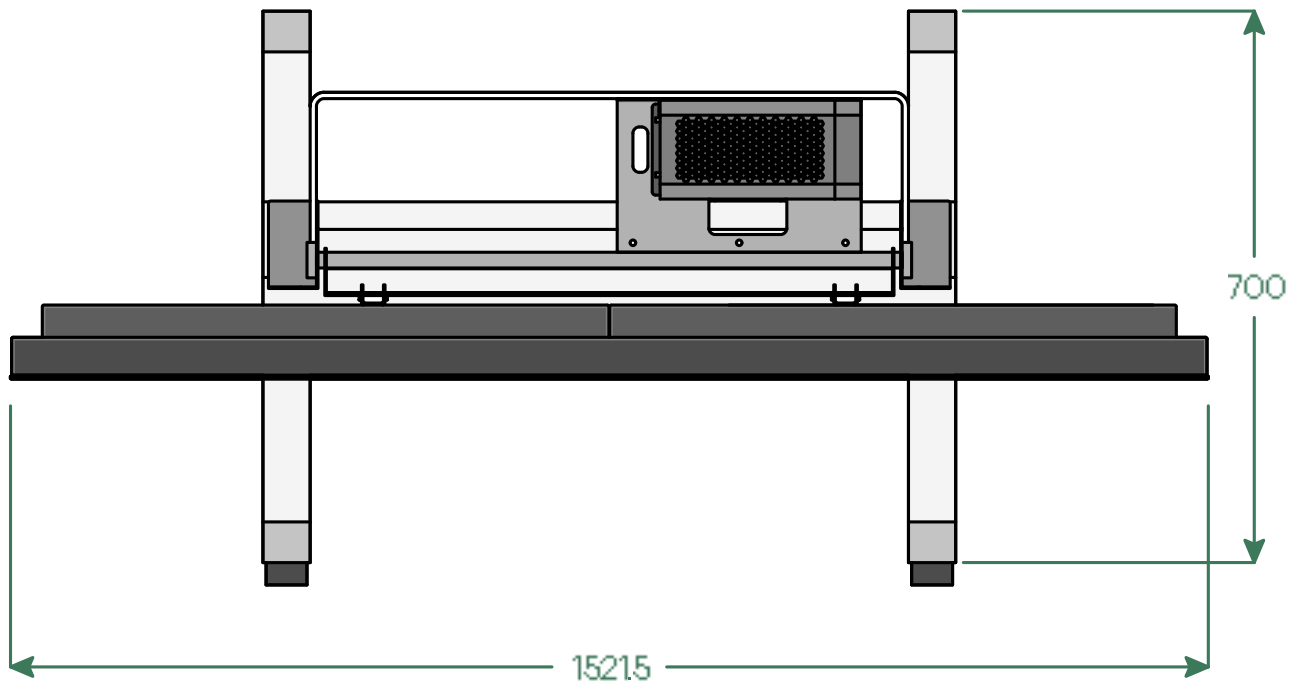



### 9.2.9. Vertical - front view (high)

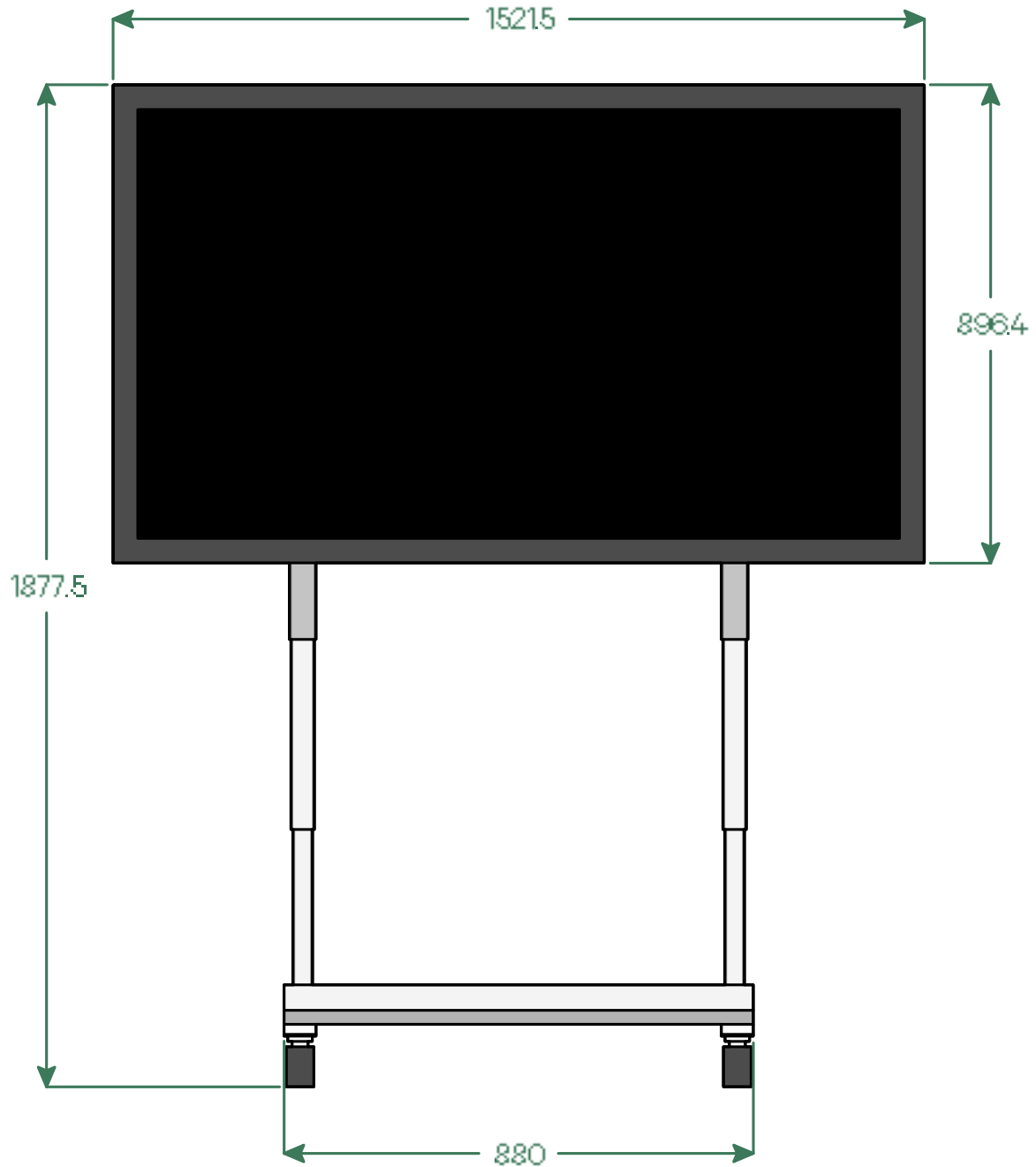

9.2.10. Vertical - front view (deep)

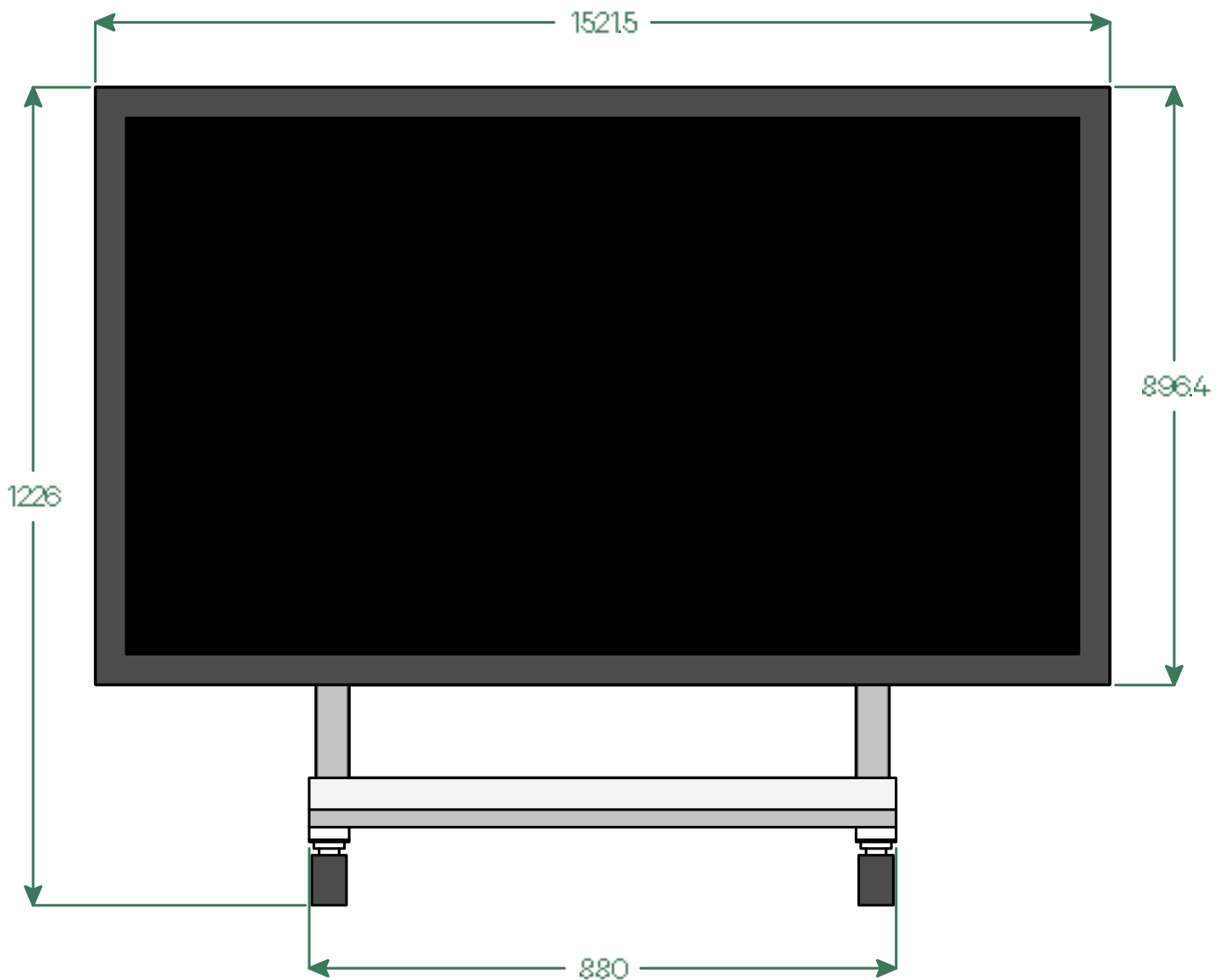

9.2.11. Vertical - side view, right (high)

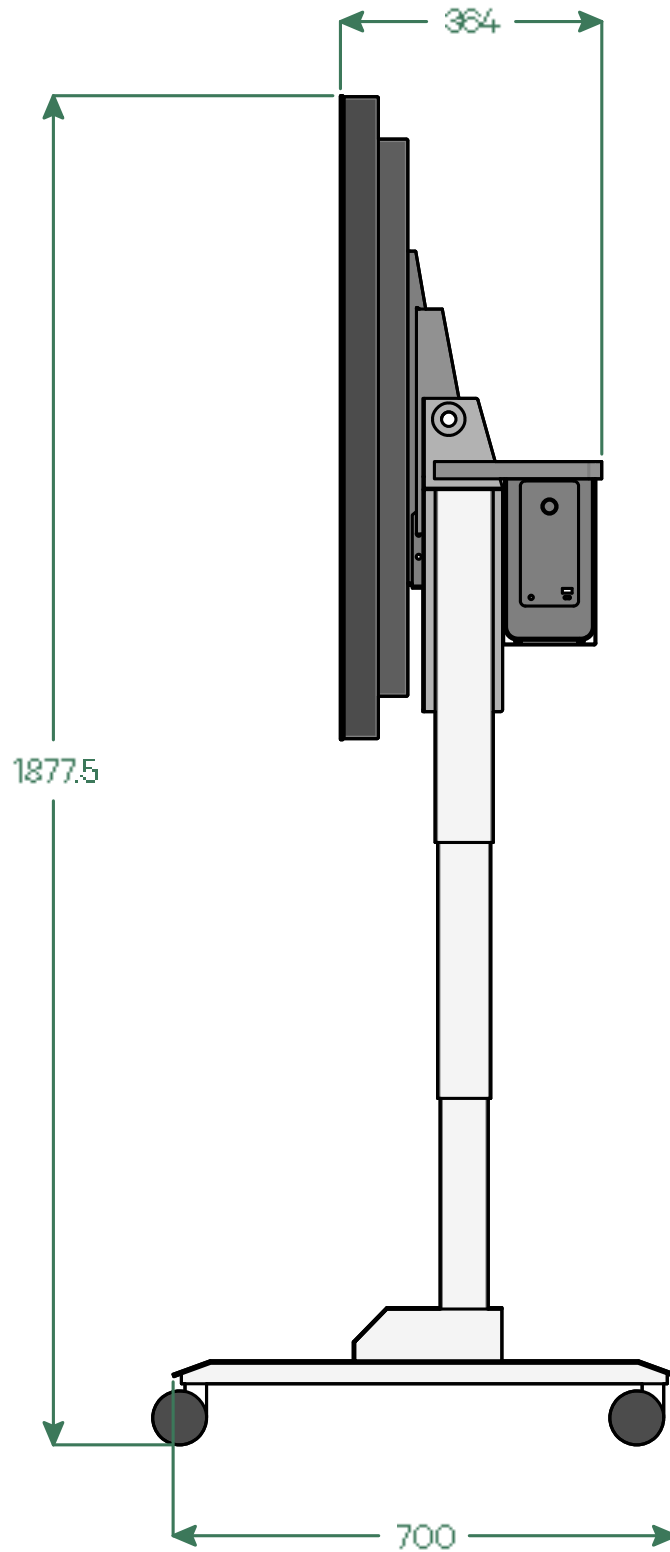

9.2.12. Vertical - side view, right (deep)

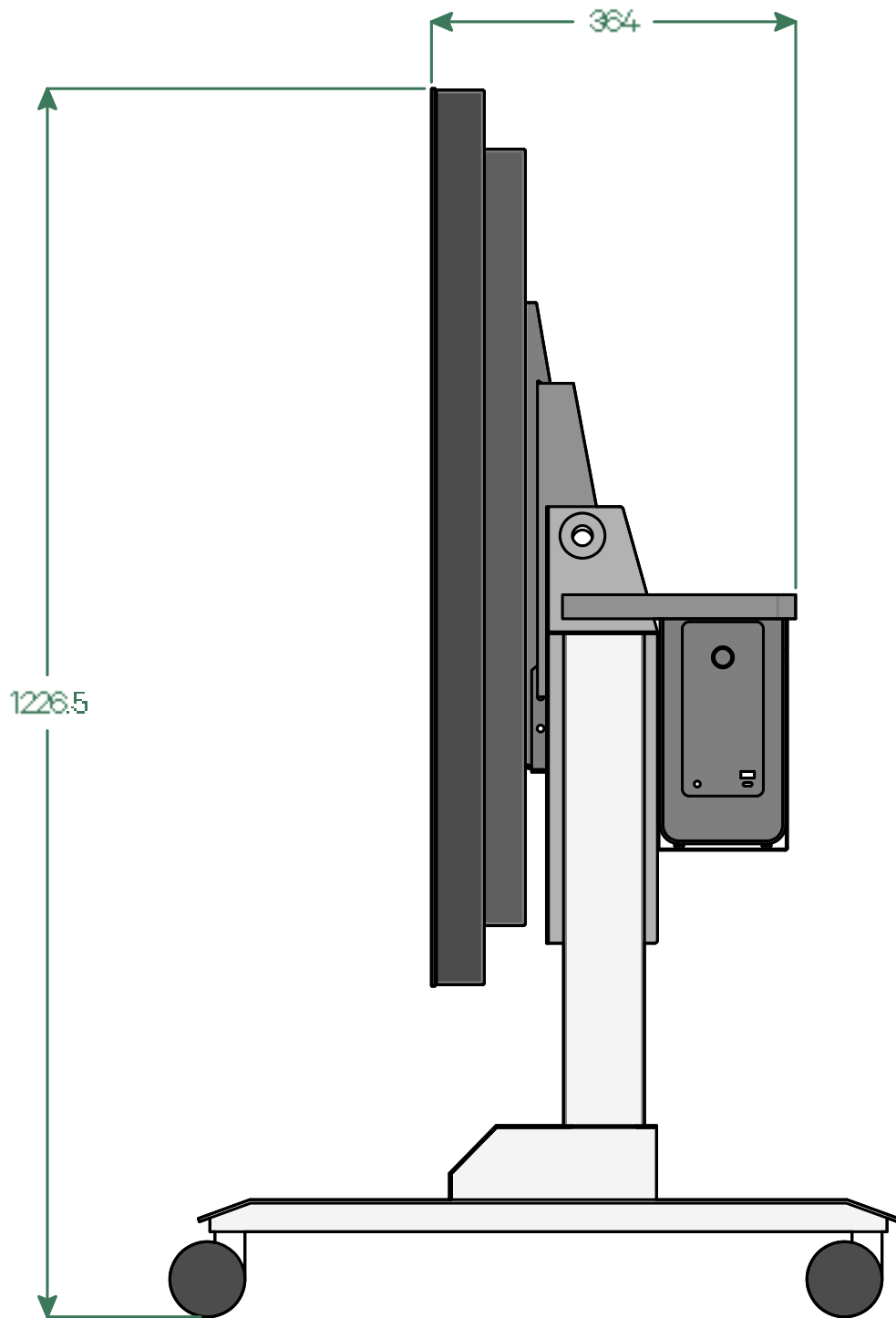

**Interactive Scape GmbH**

Wilhelmine-Gemberg-Weg 6, D-10179 Berlin T  
+49 30 69 809 41-00, F +49 30 69 809 429

[www.interactive-scape.com](http://www.interactive-scape.com), [info@interactive-scape.com](mailto:info@interactive-scape.com)